

AUTOMATED MOISTURE EVOLUTION ANALYSIS (MEA)

M. TODOKI, K. TANIGUCHI, T. HOSOI and K. ISHIKIRIYAMA
Toray Research Center Inc., 3-2-1 Sonoyama, Otsu 520 (Japan)

ABSTRACT

A commercially available moisture evolution analyzer based on coulometry was modified so that a linear or stepwise increase in temperature could be applied to samples. In addition, a data acquisition and processing system was developed using a personal computer. Application to various kinds of solid materials exemplified that our MEA technique can be regarded as one of quantitative EGD techniques according to the definition by ICTA.

INTRODUCTION

DuPont Company sells MEA apparatus based on coulometry available to solid material, where water evolved by heating sample is adsorbed onto P_2O_5 and electrolyzed into H_2 and O_2 . The charge required for electrolyzing is integrated and displayed as a total moisture content in micrograms.

It is important for materials characterization to know precise evolution behavior of water as a function of temperature or time. That is why we decided to modify the as-supplied MEA apparatus in order to constitute a definitive MEA apparatus. Bush et. al.¹ made the protomodification to analyze asbestos in 1982, although we had finished our modification except the computerization as of 1978 and have been supplying the data domestically.

EXPERIMENTAL

Apparatus, Data Acquisition and Processing: Figure 1 shows the block diagram of MEA apparatus cited from the instruction manual of DuPont Company² where the area surrounded by dashed lines indicates the portion modified by us.

Thermal Controller SSC-575 of SEIKO I & E Ltd (Japan) was connected to the DuPont's MEA 902H. A power heater and thermocouple attached to the as-purchased MEA apparatus were replaced by a

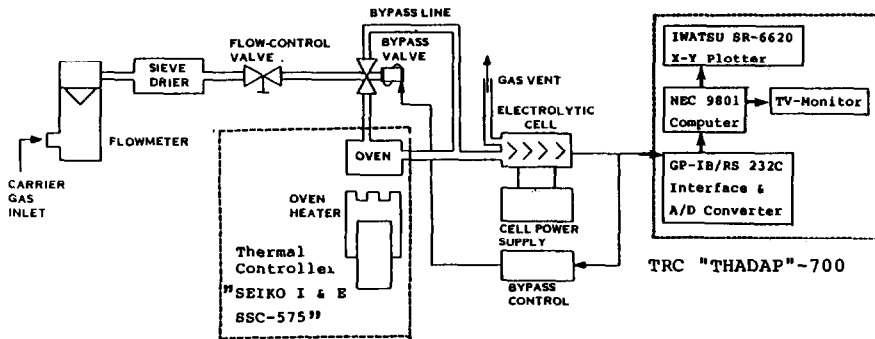

Fig.1 Block Diagram of Automated MEA² (: modified portion)

nichrome high power heater and Chromel-Alumel thermocouple, respectively. These modifications ensure to us an exactly linear or step-wise increase in temperature up to 800 °C at the highest heating rate of 40 °C/min, measuring the temperature at the spot much closer to the sample. Peak temperatures of MEA curve were confirmed to coincide with those of the DSC curve of the same sample when their comparison was possible.

The output of the apparatus in $\mu\text{g}/\text{sec}$ is transferred to a personal computer NEC 9801 by way of an A/D converter and GP-IB/RS 232C interface. The home-made computer program written in C-Language draws a figure on IWATSU SR-6620 X-Y plotter as well as TV monitor. The figure consists of a curve for the rate of moisture evolution (MEA curve) and that for an integrated moisture (integrated MEA curve) as a function of temperature or time. The temperature curve as a function of time can be added. A table for the amount of water evolved up to desired temperatures or times can also be put out in the figure in the unit of μg , % or ppm.

Materials: Cupric sulfate, Asbestos and Talc as inorganics, and Polyethylene terephthalate and Polyimide as organics were used for the measurements to exemplify the capabilities of the instrument.

Procedure: A nickel boat with a weighed sample was placed in the oven and heated at 2 or 10 °C/min after standing for a desired period at room temperature. This standing period will be shown to have a significant meaning to get rid of adsorbed water on the surface of the sample. A duplicate run was made for an empty boat. The obtained data were subtracted from the raw data of the sample automatically by the computer. The calibration was conducted

mainly using an as-supplied micropipet which contains $1980 \pm 40 \mu\text{g}$ -water. The correction factor determined after making an empty run in the same way described above was put in the computer. So the computer output always gives the corrected one using this factor. The calibration was done for every batch of experiment.

RESULTS AND DISCUSSION:

Cupric sulfate, $\text{CuSO}_4 \cdot 5\text{H}_2\text{O}$ (Fig.2): A 5 mg-sample was heated at a rate of $2^\circ\text{C}/\text{min}$ after standing at room temperature for 25 min. A well known dehydration of 3 steps is observed. The integrated MEA curve tells the total amount of evolved water of 35.7 % which is identical with the calculated one (36.1). Fig.2 also shows the full format of the data output.

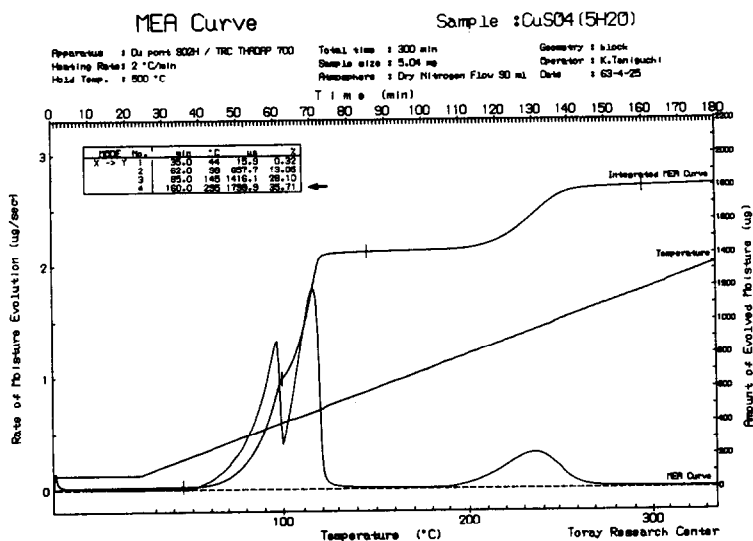

Fig. 2

Polyethylene terephthalate (Fig.3): A 300 mg-sample in glassy state was heated at $10^\circ\text{C}/\text{min}$ up to 280°C where it was held isothermally. It should be stressed that the whole moisture evolution profile against temperature can be clearly recognized in the MEA curve although the total amount of water is very small (0.49%). It is, moreover, interesting to note that the rate of evolution is accelerated between the glass transition and cold crystallization of which presences can be seen in the DSC curve reproduced from our data stock. This observation is quite reasonable because the rate of moisture evolution from liquid state is expected to be faster than that from solid state.

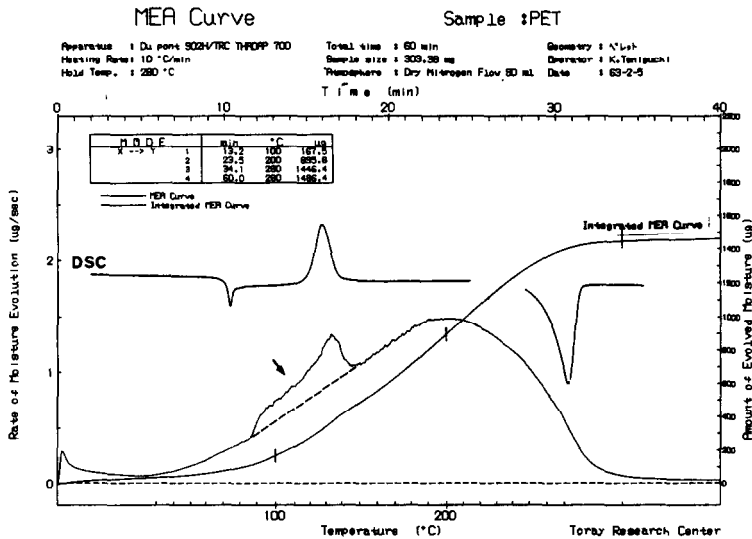

Fig.3

Polyimide films, "Kapton" (Fig.4): Two types of "Kapton" films (12.5 µm and 125 µm) were analyzed. Their 100 mg were heated at 10 °/min up to 500 °C after standing at ambient temperature for 60 min. The first peak during the standing is due to desorption of the water adsorbed on the film surface. The second peak around 100 °C is assigned to release of the water absorbed inside the sample. Note the difference in peak heights between the two types of samples: the first peak of the 12.5 µm-sample is higher than that of the 125 µm-one; the opposite is observed with the second.

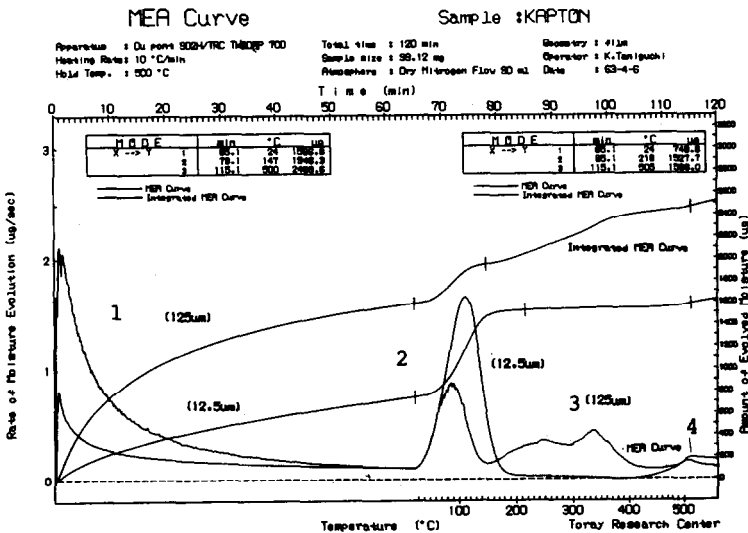

Fig.4

The former is obviously due to the difference in surface area. The third peak existing only with the thicker sample from ca. 150 °C to 400 °C may be due to residual ring closure. The fourth moisture peak may be an indication of the beginning of the thermal decomposition.

Asbestos, "Chrysotile" (Fig.5): A 10 mg-sample was heated up to 800 °C at 10 °C/min. The large peak around 600 °C is assigned to dehydration reaction of chrysotile to forsterite. The moisture amounts to 10.6% which is converted to 11.1 % provided any evolution is not observed below 450 °C. The peak around 400 °C of 2.5 % surely originates from dehydroxylation of brucite, $Mg(OH)_2$ as one of impurities in chrysotile. Several small peaks below 300 °C may be due to dehydration of other impurities we cannot tell about, the initial peak being assigned to the surface water. Other types of asbestos are going to be analyzed.

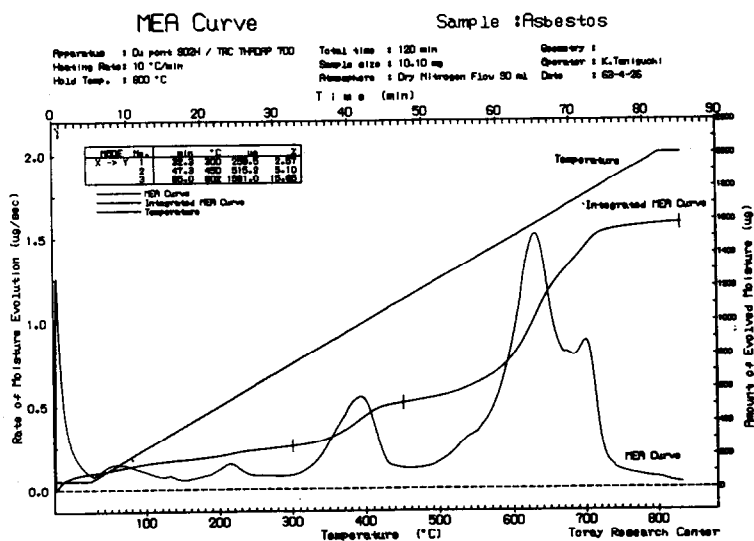

Fig.5

Talc (Fig.6): Two types of talc (Italian talc and Indian one) were heated up to 750 °C at 10 °C/min in order to investigate the difference in their geographical sources. After the 2-step release of adsorbed water below ca. 200 °C, i.e., the ones before and after heating, moisture continues to evolve at a small but constant rate up to at least 500 °C. This water could be assigned to the interlayer bound water which is believed to exist in some kinds of clays. The evolved water around 600 °C is due to dehydroxylation

of impurities in the talcs. This assignment is based on the two facts: the amount of evolved water strongly depends on the geographical source as Fig. 6 shows; it was not until 800 °C, according to their TG curves not shown here, that the dehydroxylation of the talcs themselves started. The total amounts of evolved moisture are 0.951 % for Italian talc and 0.623 % for Indian talc. The high resolution of the MEA curves irrespective of the small values of the total moisture should be also noted.

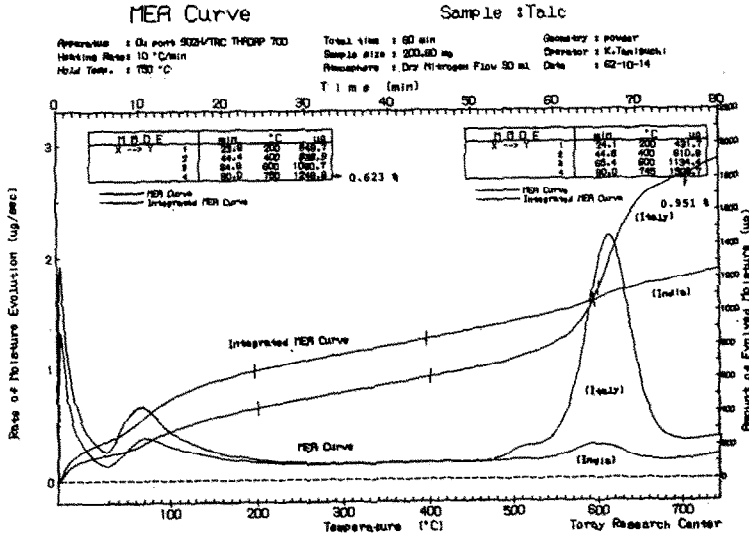

Fig. 6

CONCLUSION

A commercially available MEA apparatus was modified so that a linear or stepwise increase in temperature could be applied to samples and quantitative MEA curves could be yielded. By applying this technique to various solid materials, we reached the conclusion that our automated MEA apparatus can be regarded as one of the thermal analysis techniques defined by ICTA.³

REFERENCES

1. D. G. Bush and R. A. Schmacher; *Anal. Chem.*, **54**, 1792 (1982).
2. Instruction Manual of MEA, DuPont Company.
3. G. Lombardi; "For Better Thermal Analysis", 2nd ed. (ICTA, 1980).